

# SENSYS TG-DSC

Simultaneous  
TGA and 3-D DSC  
From -120 °C to 830 °C  
by Setaram



A trademark of KEP Technologies group

# SENSYS TG-DSC



The SENSYS evo TG-DSC offers the most precise DSC sensor together with a truly symmetrical microbalance to give YOU a combined TG-DSC system with totally unmatched performance. Additionally both measurement sensors are totally independent, so can be operated independently or simultaneously without compromising performance.

## HIGHLIGHTS include:

### Differential Scanning Calorimeter

- **Incomparable precision:** the unique 3D DSC sensor totally surrounds your sample and reference crucibles so that the entire energy of any transformation is monitored thereby giving you an unequalled accuracy of measurement.
- **Parameter Independent Calibration:** because of the 3D transducer the calibration of **SENSYS evo** is independent of:
  - mass and form (powder, fibre, liquid, etc.) of the sample,
  - contact between the sample and the transducer,
  - crucible type,
  - sweeping gas (inert, oxidizing, reducing, wet, pressure) and flow rate.

### Thermogravimetry

- **Excellent TG signal baseline:** the symmetry of the microbalance, with its sample and reference suspended vertically from the beam guarantee reproducible positioning of the sample over time and excellent stability of the TG signal baseline.
- **Automatic compensation of Buoyancy:** the sample and the reference are heated inside the same calorimetric block (symmetrical furnace), which means that the buoyancy effect is automatically compensated.

**Ease of operation:** dedicated market leading **CALISTO** software that is not only intuitive but powerful enough to perform every typical experiments and data treatment.

## 3D DSC SENSOR

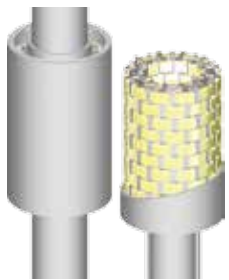

3D Sensor

The sample and reference sensors are composed of 120 thermocouples mounted in a cylinder that totally surrounds the measurement zone. These two cylinders can measure up to 94 % of all heat exchanged with the sample/reference, as compared to 20 % typically (50 % absolute maximum) with 2D place sensors.

The sensors are mounted in a calorimetric block that is further water cooled to eliminate any environmental variations and therefore giving you a highly precise and robust sensor with a unique level of specific sensitivity. For studies at sub-ambient temperature, an automated cooling device utilizing evaporation of liquid nitrogen can be fitted onto the calorimetric unit.

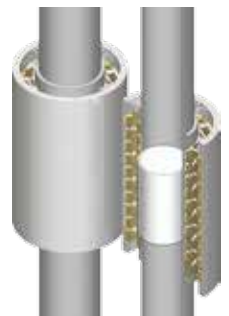

See *SENSYS TG-DSC evo* application notes



## SENSOR RODS

### **Simultaneous TG & DSC**

The performances of the SENSYS evo TG-DSC result from the absolute symmetry of this unique system in which the TG and DSC transducers, which are mechanically independent, retain their specific characteristics:

- **symmetry of the furnace:** the sample and the reference are heated inside the same calorimetric block, which means that the buoyancy effect is compensated automatically
  - **symmetry of the upper beam microbalance:** its vertical design with beams of identical length guarantees perfectly reproducible positioning of the sample over time and excellent stability of the TG signal baseline
- The SENSYS evo TG-DSC is an extremely sensitive instrument that can measure actual variations in weight of the order of one microgram.

### **Gas control panel**

The SENSYS evo TG-DSC incorporates an automated gas control panel. It is possible to:

- select from 3 different carrier gases (flow rate: 4 to 200 ml/min)
- mix one of these carrier gases with another "auxiliary or reactive" gaseous fluid (flow rate: 0.3 to 16 ml/min)

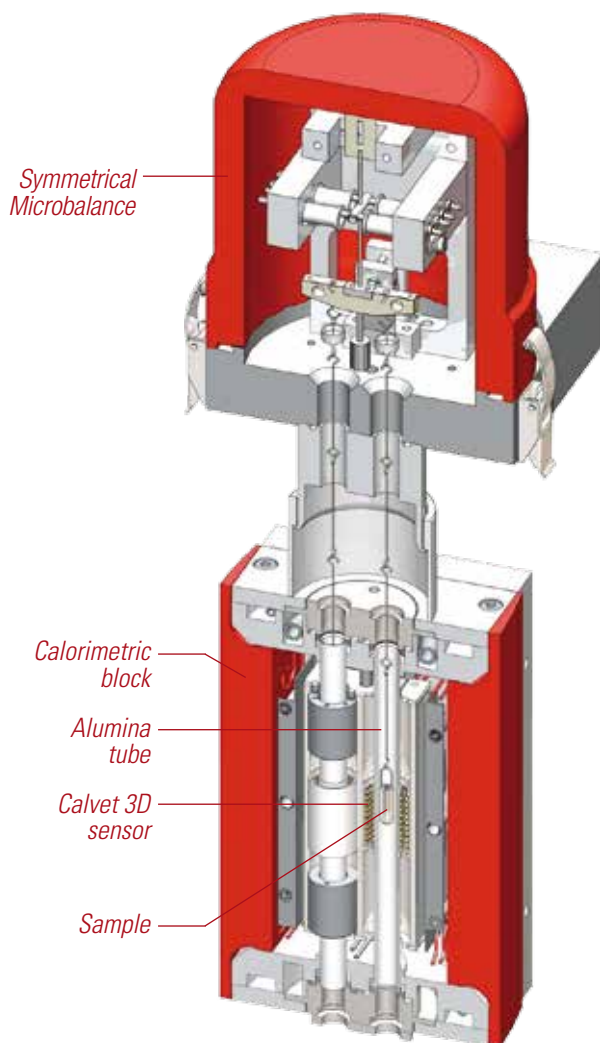

## CRUCIBLES

Crucibles of 150 µl capacity are available in aluminium, alumina, platinum or silica to suit the chemical nature of the sample. A silica tube can be added to protect the transducer and the analysis chambers during test involving sweeping with corrosive gas.

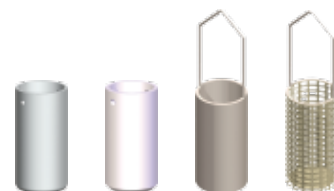

## EVOLVED GAS ANALYSIS

The SENSYS evo design features both a small furnace volume and also an easily accessible exhaust to allow for direct connection to further analysis devices such as MS, FTIR, GC etc. without excessive sample dilution or long transfer lines. Setaram offers a range of transfer lines and software solution for system comprehensive integration.

To date SENSYS has also been successfully coupled with:

- FTIR/MS and GC
- Gas Sorption devices
- An X-ray absorption spectroscopy apparatus

## MEASUREMENTS UNDER CONTROLLED HUMIDITY

Humidity is known to have a significant influence on the stability of many materials. In order to evaluate this specific influence, SETARAM has developed WETSYS a controlled humidity generator. It can:

- deliver a very precise level of relative humidity (RH) from 5 to 95 % depending on the temperature and measure the humidity around the sample.
- be connected to SETARAM instruments, and in particular to the SENSYS evo TG-DSC as well as other analysis instrument (RX, GC, etc.) for studies of sorption, hydration, stability, etc.

See SENSYS evo DSC brochure

## APPLICATIONS

With its high precision and wide temperature range (-120 to 830 °C) the **SENSYS evo TG-DSC** has a wide range of applications, especially in the fields of thermodynamics (Specific Heat Capacity Cp accuracy within +/-1 %), pharmaceuticals (phase diagram, polymorphism, purity, thermal stability), safety of chemical process (transition, decomposition under high pressure), energy (catalysis, hydrogen storage, hydrogen adsorption), polymers (glass transition, measurement under pressure), etc.

View the application notes in your field, available for download, by visiting [www.setaram.com!](http://www.setaram.com!)

A huge database is in the [application library area](#) of our website. We have also included a powerful search engine that will enable you to find the most applicable data.

## SPECIFICATIONS

<b>Temperature range</b>	Ambient to 830 °C
<b>With cooling accessories</b>	-120 °C to 200 °C (Liquid Nitrogen Accessory)
<b>Temperature accuracy</b>	+/-0.1 °C
<b>Programmable temperature scanning rate</b>	0.01 to 30 °C min <sup>-1</sup>
<b>DSC</b>	
<b>Calorimetric Precision</b>	+/-0.1 %
<b>RMS Noise</b>	0.2 µW
<b>Resolution</b>	0.35 µW / 0.035 µW
<b>Gases</b>	3 carrier gases (MFC from 4 to 200 ml/min) + 1 auxiliary or reactive gas (MFC from 0.3 to 16 ml/min)*
<b>Pressure option (non controlled)</b>	High Pressure Crucible (up to 500 bars / 7250 psi at 600 °C)
<b>Pressure option (measured &amp; controlled)</b>	High Pressure Crucible (up to 350 bars / 5800 psi at 800 °C)
<b>TG</b>	
<b>Maximum balance capacity</b>	3 g
<b>Weight range</b>	+/-200 mg
<b>Weighing precision</b>	+/-0.01 %
<b>TG Resolution</b>	0.02 µg, 0.002 µg
<b>Baseline dynamic drift</b>	< 10 µg
<b>Isothermal temperature accuracy</b>	+/-0.1 °C
<b>Vacuum</b>	< 10-1 mbar
<b>Evolved gas</b>	MS, FTIR, GC couplings
<b>Weight</b>	55 kg (121 lbs)
<b>Dimensions (Height / Width / Depth)</b>	60 closed, 80 opened / 53 / 58 cm (23,6 closed, 31.4 opened / 20.9 / 22.8 in)
<b>Power requirements</b>	230 V - 50/60 Hz

Option : AKTS Thermokinetics software for comprehensive investigation of reaction or decomposition



\*MFC = Mass Flow Controller

pirana.net • Specifications are given as indications only and are not contractual • 10/14

## CONTACTS



SETARAM Instrumentation  
7 rue de l'Oratoire  
69300 Caluire - France  
Phone +33 (0)4 72 10 25 25  
Fax +33 (0)4 78 28 63 55

[www.setaram.com](http://www.setaram.com)  
[sales@setaram.com](mailto:sales@setaram.com)

Offices in United States, China, Germany, Russia

A trademark of KEP Technologies group

